

Technical report 12-003

Existence Conditions for an Optimal Affine Leader Function in the Reverse Stackelberg Game*

N. Groot, B. De Schutter, and H. Hellendoorn

To cite this work, please refer to the published version:

N. Groot, B. De Schutter, and H. Hellendoorn, "Existence conditions for an optimal affine leader function in the reverse Stackelberg game," *Proceedings of the 15th IFAC Workshop on Control Applications of Optimization (CAO'12)*, Rimini, Italy, pp. 56–61, Sept. 2012. doi:[10.3182/20120913-4-IT-4027.00016](https://doi.org/10.3182/20120913-4-IT-4027.00016)

Delft Center for Systems and Control
Delft University of Technology
Mekelweg 2, 2628 CD Delft
The Netherlands
phone: +31-15-278.24.73 (secretary)
URL: <https://www.dcsc.tudelft.nl>

* This report can also be downloaded via <https://dpub.eu/12-003>

Existence Conditions for an Optimal Affine Leader Function in the Reverse Stackelberg Game

Noortje Groot* Bart De Schutter* Hans Hellendoorn*

* Delft Center for Systems and Control, Delft University of Technology, Delft, The Netherlands. E-mail: n.b.groot@tudelft.nl

Abstract: We investigate the solvability of the reverse Stackelberg game. Here, a leader player acts first by presenting a leader function that maps the follower decision space into the leader decision space. Subsequently, the follower acts by determining his optimal decision variable. Such a game setting can be adopted within a multi-level optimization approach for large-scale control problems like road tolling. However, due to the complexity of the general game, results often rely on specific examples. As a starting point towards developing a systematic approach for the use of reverse Stackelberg games in control, a characterization of cases is given in which the desired leader equilibrium can be achieved by an affine leader function. Here, we focus on the single-leader single-follower deterministic, static (one-shot) case. This characterization follows a geometric approach and extends the special cases considered in the existing literature to also incorporate the more general case in which nonconvex and nonsmooth sublevel sets apply.

Keywords: Stackelberg games, hierarchical decision making, existence conditions

1. INTRODUCTION

In the context of large-scale control problems, smart optimization methods have to be implemented in order to obtain a good performance in an acceptable time frame. Whereas a centralized approach is intractable in large-scale networks, a decentralized method generally yields an insufficient performance. A distributed control approach may work efficiently, yet in networks where a natural division in levels applies, e.g., due to the operation of controllers on different time scales and sizes of a network, a multi-level approach may fit better (Scattolini, 2009).

In multi-level control, a leader-follower game structure can be applied as a means to structure and facilitate the problem solving. The reverse Stackelberg game is such a game (Ho et al., 1981), also known in the control community under the concept ‘incentives’ (Ho et al., 1982) and more recently as inverse Stackelberg game (Olsder, 2009). Whereas the original Stackelberg game considers a hierarchical framework in which leader and follower player act sequentially by presenting their decision variable values (von Stackelberg, 1934), in the reverse Stackelberg game the leader action is of a different type. Here, the leader acts first by presenting a mapping of the follower decision space into the leader decision space, after which the follower still acts by determining his optimal decision variable.

Since the 1970s, several results have been obtained on both static and dynamic (open and closed-loop or feedback) Stackelberg games (Simaan and Cruz, Jr., 1973; Tolwinski, 1981) and reverse Stackelberg games (Li et al., 2002), also considering cases with uncertainty (Başar, 1984; Cansever and Başar, 1985b,a). Other extensions include partial information (Zheng and Başar, 1982) and different time

scales of operation (Salman and Cruz, Jr., 1983). More recently, results in Stackelberg games have included switching positions of leader and follower (Nie, 2010; Başar et al., 2010). However, it should be emphasized that the game is complex due to e.g., the composed functions involved (Olsder, 2009). Nonetheless, the game has been applied to network pricing (Shen and Başar, 2007) and electricity pricing (Luh et al., 1982) as well as to road tolling problems (Staňková et al., 2009). Still, current research mostly remains restricted to the special case of an affine leader function in applications with convex, quadratic cost functions and, in the dynamic case, linear state equations (Ehtamo and Hämmäläinen, 1985). In particular, in Zheng and Başar (1982) some conditions were developed for the existence of an optimal affine leader function, arguing that the class of problems with a differentiable and strictly convex follower objective function is sufficiently large. Nonetheless, real-life control problems occur with many different structures.

In the current paper, necessary and sufficient conditions are therefore presented for the existence of an affine leader function that returns the desired reverse Stackelberg equilibrium. Here, existing sufficiency results for the strictly convex case are extended, considering also nondifferentiable objective functions and sublevel sets. Moreover, the convexity requirement of the follower’s objective function is relaxed and later on a constrained decision space is considered. The extension is not so trivial, as will be illustrated by some examples. While this extension is only a first step in relaxing the assumptions made so far, it aims towards extending and developing a structured approach for solving more general subclasses of this complex game.

The remainder of this paper is structured as follows. After the definition of the reverse Stackelberg game in

Section 2, some preliminary notation and assumptions are stated. In Section 3 the affine leader function structure is presented, after which the existence results for an optimal affine leader function for a convex respectively nonconvex sublevel set are presented in Section 4 and 5. Section 6 includes a brief analysis of the constrained case and the paper is concluded in Section 7.

2. PRELIMINARIES

2.1 The Reverse Stackelberg Game

In the following definition of the reverse Stackelberg game, we assume that the leader seeks to achieve a unique global optimum (u_L^d, u_F^d) of leader and follower inputs $u_L^d \in \Omega_L \subseteq \mathbb{R}^{n_L}$, $u_F^d \in \Omega_F \subseteq \mathbb{R}^{n_F}$. The problem then becomes for the leader to determine an optimal leader function $\gamma_L : \Omega_F \rightarrow \Omega_L$ that leads to this equilibrium. In the case of multiple optima, the leader may choose any of them as the desired solution. Further, leader and follower objective functions are denoted $\mathcal{J} : \Omega_L \times \Omega_F \rightarrow \mathbb{R}$ and Γ_L denotes the class of admissible leader functions in a particular game context.

$$\text{To find: } \gamma_L \in \Gamma_L, \gamma_L : \Omega_F \rightarrow \Omega_L \quad (1)$$

$$\text{s.t. } \arg \min_{u_L \in \Omega_L, u_F \in \Omega_F} \mathcal{J}_L(u_L, u_F) = (u_L^d, u_F^d), \quad (2)$$

$$\arg \min_{u_F \in \Omega_F} \mathcal{J}_F(\gamma_L(u_F), u_F) = u_F^d, \quad (3)$$

$$\gamma_L(u_F^d) = u_L^d. \quad (4)$$

In other words, the leader should construct her function γ_L such that it passes through her desired optimum but such that it does not touch other points in the sublevel set

$$\Lambda_d := \{(u_L, u_F) \in \Omega_L \times \Omega_F \mid \mathcal{J}_F(u_L, u_F) \leq \mathcal{J}_F(u_L^d, u_F^d)\}.$$

For such γ_L the follower will select u_F^d under the minimization of his objective function.

As a first step in our analysis of the problem, we like to know under what conditions the leader is able to induce the follower to choose the input u_F^d and thus reach the desired solution. The property of a particular equilibrium to be feasible for an instance of the reverse Stackelberg game is known as incentive compatibility (Ho et al., 1982). In this paper, linear incentive compatibility will be considered, i.e., regarding an affine structure of γ_L .

2.2 Notation

The reader is assumed to be familiar with some concepts occurring in convex analysis and geometry, such as hyperplanes and strictly convex functions and sets (see e.g., Auslender and Teboulle (2003); Rockafellar (1970); Dattorro (2005)). In addition, we will use the following definitions:

- $\Pi_X(x)$ denotes a supporting hyperplane to the set X at the point $x \in X$.
- As in Auslender and Teboulle (2003) a set X is an affine subspace if $y, z \in X \iff \alpha y + (1 - \alpha)z \in X \forall \alpha \in \mathbb{R}$.
- As in Dattorro (2005), a vertex point or exposed point v of a convex set X is defined as a point in its closure \bar{X} that intersects with a strictly supporting hyperplane. Similarly, a point \tilde{x} in the closure of a

nonconvex set \bar{X} is a vertex point if there exists a neighborhood of \tilde{x} , $\mathcal{N}(\tilde{x})$, such that \tilde{x} intersects with a strictly supporting hyperplane to $\mathcal{N}(\tilde{x})$.

- The projection of a vector v on the vector x is denoted $\text{proj}_x(v)$. The projection of the set $P \subseteq \mathbb{R}^n$ onto the space $X = \mathbb{R}^m$, $m \leq n$ is denoted $\text{proj}_X(P)$.
- By $\{0\}^{n_L} \times \Omega_F$ we denote the decision space in which the leader components are taken to be zero.
- A generalized gradient $\partial f(x)$ of a locally Lipschitz continuous function $f : \mathbb{R}^n \rightarrow \mathbb{R}$ at x is defined as follows: $\partial f(x) := \text{conv}(\{\lim_{m \rightarrow \infty} \nabla f(x_m) \mid x_m \rightarrow x, x_m \in \text{dom}(f) \setminus \Omega_f\})$, with Ω_f being the set of points where f is nondifferentiable and where no limit $\lim_{m \rightarrow \infty} \nabla f(x_m)$ exists (Clarke, 1983). By $\mathcal{V}(X(x))$ we denote the generalized normal to the set X at the point $x \in \bar{X}$, defined as the set of normal vectors to the possible tangent hyperspaces to X at x .

2.3 Assumptions

[A.1] Let Ω_L, Ω_F be convex sets.

[A.2] Let Λ_d be a connected set.

[A.3] Let n_L, n_F be finite.

[A.4] Let $\Lambda_d \neq \{(u_L^d, u_F^d)\}$.

The first assumption is taken from the literature on Stackelberg games, e.g., Zheng and Başar (1982); Başar and Olsder (1999), and is required for convexity of \mathcal{J}_F and Λ_d . Assumption [A.2] is a less restricted case of taking \mathcal{J}_F and therefore also Λ_d to be strictly convex, as done in Zheng and Başar (1982). Note that [A.2] is automatically satisfied if it holds that \mathcal{J}_F is a convex or quasiconvex function. Assumption [A.3] is necessary in order to use the concept of a supporting hyperplane and it is an accepted assumption in many control applications (Åström and Wittenmark, 1997). Finally, the special case excluded by assumption [A.4] presents the trivial situation in which (u_L^d, u_F^d) is automatically optimal for the follower.

3. AN AFFINE LEADER FUNCTION

In the following we assume an affine leader function $\gamma_L : \Omega_F \rightarrow \Omega_L$, i.e., of the form

$$u_L := \gamma_L(u_F) = u_L^d + B(u_F - u_F^d), \quad (5)$$

with B a linear operator mapping $\Omega_F \rightarrow \Omega_L$, represented by an $n_L \times n_F$ matrix in the considered finite-dimensional case.

Recall from the definition of the reverse Stackelberg game that the variable u_F^d is optimal for the follower if and only if $\gamma_L \cap \Lambda_d = \{(u_L^d, u_F^d)\}$. Recall also that a supporting hyperplane intersects solely with points on the boundary of a set. Therefore, in the following results we make use of the latter concept, requiring γ_L to lie on a strictly supporting hyperplane $\Pi_{\Lambda_d} : \Pi_{\Lambda_d} \cap \Lambda_d = \{(u_L^d, u_F^d)\}$. Here, γ_L can be described as an affine hyperspace of dimension n_L , i.e., it is a subset of an $(n_L + n_F - 1)$ -dimensional hyperplane.

From now on, we denote by \mathcal{A}_L the set of affine relations through (u_L^d, u_F^d) defined as sets of dimension n_F in $\Omega_L \times \Omega_F$ and such that for $\alpha_L \in \mathcal{A}_L$, $\alpha_L \cap \Lambda_d = \{(u_L^d, u_F^d)\}$. Note that this construction is necessary in order to be able to work with the function $\gamma_L : \Omega_F \rightarrow \Omega_L$ as a set of points $\{(u_L, u_F) \mid u_F \in \Omega_F, u_L = \gamma_L(u_F)\}$. For $\alpha_L \in \mathcal{A}_L$, $\alpha_L(\Omega_L) = \Omega_F$, we can then characterize a candidate leader function by $\gamma_L := (\alpha_L)^{-1}$. Finally, let $\mathcal{A}_L^{\Pi_{\Lambda_d}} := \{\alpha_L \in \mathcal{A}_L \mid \alpha_L \subseteq \Pi_{\Lambda_d}\}$.

For the sake of clarity, we now provide a high-level summary of the results presented in the remainder.

Overview of Results	
• Unconstrained decision space	
[4] Λ_d convex	- \mathcal{J}_F differentiable (Thm. 5)
	- \mathcal{J}_F nondifferentiable, Λ_d smooth (Remark 6)
	- Λ_d nonsmooth (Thm. 7)
[5] Λ_d nonconvex	
[A] $n_L = 1$	- \mathcal{J}_F differentiable (Prop. 11)
	- Λ_d nonsmooth (Prop. 12)
[B] $n_L > 1$	- $(u_L^d, u_F^d) \notin \text{int}(\text{conv}(\Lambda_d))$ (Prop. 13)
	- $(u_L^d, u_F^d) \in \text{int}(\text{conv}(\Lambda_d))$ (Prop. 14)
• Constrained decision space [6]	

4. Λ_d CONVEX

In the following, results of Zheng and Başar (1982) are extended into a stronger, necessary and sufficient condition (Theorem 5) and subsequently formulated for the case of a nonsmooth sublevel set (Theorem 7). Some special cases are further pointed out in several remarks. It should be noted that when relaxing the strict convexity of the follower objective function, the desired leader equilibrium is not automatically a boundary point of the sublevel set. Exclusion of this case prevents the current theory from being generally applicable.

Lemma 1 and 2 required for the remainder of the analysis follow automatically from the supporting hyperplane theorem (e.g., Theorem 11.6 in Rockafellar (1970)) and the definition of a strictly supporting hyperplane.

Lemma 1. Assume Λ_d to be convex. Let $\Omega_L = \mathbb{R}^{n_L}, \Omega_F = \mathbb{R}^{n_F}$ and let $\alpha_L \in \mathcal{A}_L$ be any affine function through (u_L^d, u_F^d) such that $\alpha_L \cap \Lambda_d = \{(u_L^d, u_F^d)\}$. Then α_L lies on a supporting hyperplane $\Pi_{\Lambda_d}(u_L^d, u_F^d)$.

Lemma 2. Assume Λ_d to be convex and assume Λ_d to be locally strictly convex at (u_L^d, u_F^d) . Then there exists a supporting hyperplane $\Pi_{\Lambda_d}(u_L^d, u_F^d)$ that intersects with Λ_d only in the point (u_L^d, u_F^d) : $\Pi_{\Lambda_d}(u_L^d, u_F^d) \cap \Lambda_d = \{(u_L^d, u_F^d)\}$.

Remark 3. There exists a more general class of sublevel sets Λ_d that are not necessarily locally strictly convex at the equilibria (u_L^d, u_F^d) , but for which it does hold that $\exists \Pi_{\Lambda_d} : \Pi_{\Lambda_d}(u_L^d, u_F^d) \cap \Lambda_d = \{(u_L^d, u_F^d)\}$. Here we refer to the vertex points of Λ_d ; Lemma 2 can thus be extended to include sets Λ_d for which (u_L^d, u_F^d) is a vertex point. The proof would be as before where instead of the convex set Λ_d that is locally strictly convex at (u_L^d, u_F^d) , a strictly convex superset of Λ_d is considered with (u_L^d, u_F^d) still as a boundary point.

Remark 4. Consider the case with Λ_d convex and again under the relaxed property that Λ_d is no longer locally strictly convex at (u_L^d, u_F^d) . Further, let $(u_L^d, u_F^d) \notin \text{int}(\Lambda_d)$ and suppose that no supporting hyperplane $\Pi_{\Lambda_d}(u_L^d, u_F^d)$ exists that intersects with Λ_d solely in the point (u_L^d, u_F^d) . (It follows that (u_L^d, u_F^d) is not a vertex point.) By con-

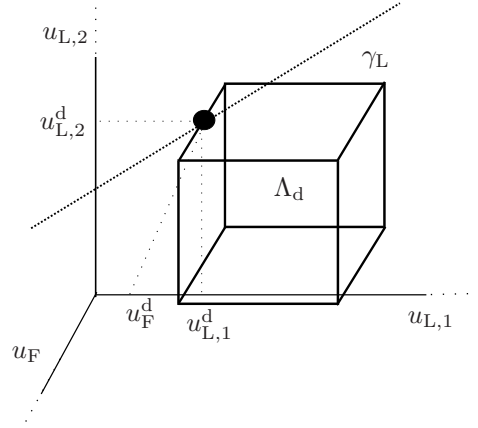

Fig. 1. Affine γ_L lying on a supporting hyperplane $\Pi_{\Lambda_d}(u_L^d, u_F^d)$ that is not strictly supporting.

vexity of Λ_d there does exist a supporting hyperplane $\tilde{\Pi}_{\Lambda_d}(u_L^d, u_F^d)$ such that $\tilde{\Pi}_{\Lambda_d}(u_L^d, u_F^d) \cap \Lambda_d \setminus \{(u_L^d, u_F^d)\} \neq \emptyset$.

For this case an optimal affine γ_L may still exist that lies on a supporting hyperplane $\tilde{\Pi}_{\Lambda_d}(u_L^d, u_F^d)$. Refer to Figure 1 for an example: although no strictly supporting hyperplane at (u_L^d, u_F^d) exists, there does exist a $\gamma_L : \gamma_L \cap \Lambda_d = \{(u_L^d, u_F^d)\}$.

Theorem 5. Let Λ_d be convex and let Λ_d be locally strictly convex at (u_L^d, u_F^d) . Additionally, let \mathcal{J}_F be differentiable at (u_L^d, u_F^d) and assume that $\Omega_L = \mathbb{R}^{n_L}, \Omega_F = \mathbb{R}^{n_F}$. Then the desired equilibrium (u_L^d, u_F^d) can be reached under an affine $\gamma_L : \Omega_F \rightarrow \Omega_L$ if and only if $\nabla_{u_L} \mathcal{J}_F(u_L^d, u_F^d) \neq 0$.

Proof. From Lemma 1 and 2 it follows that there exists an affine $\alpha_L^{\Pi_{\Lambda_d}} \in \mathcal{A}_L^{\Pi_{\Lambda_d}}$ with $\Pi_{\Lambda_d} \cap \Lambda_d = \{(u_L^d, u_F^d)\}$. Under the use of a leader function associated with $\alpha_L^{\Pi_{\Lambda_d}}$, by definition of the level set Λ_d the minimum value of \mathcal{J}_F will be obtained at (u_L^d, u_F^d) . Hence, (u_L^d, u_F^d) can be reached under an affine $\alpha_L^{\Pi_{\Lambda_d}}$.

It remains to show that in order for $\alpha_L^{\Pi_{\Lambda_d}}(\Omega_L) = \Omega_F$ to hold it is necessary and sufficient that $\nabla_{u_L} \mathcal{J}_F(u_L^d, u_F^d) \neq 0$. First note that since \mathcal{J}_F is differentiable at (u_L^d, u_F^d) the normal vector to Λ_d at (u_L^d, u_F^d) exists and is equal to $\nabla \mathcal{J}_F(u_L^d, u_F^d)$, which is unique and hence the supporting hyperplane $\Pi_{\Lambda_d}(u_L^d, u_F^d)$ is unique, i.e., it is a tangent hyperplane corresponding to the equation

$$\nabla_{u_F}^T \mathcal{J}_F(u_L^d, u_F^d)(u_F^d - u_F) + \nabla_{u_L}^T \mathcal{J}_F(u_L^d, u_F^d)(u_L^d - u_L) = 0. \quad (6)$$

(\Rightarrow) By contraposition: Suppose that $\nabla_{u_L} \mathcal{J}_F(u_L^d, u_F^d) = 0$. Then $\Pi_{\Lambda_d}(u_L^d, u_F^d)$ will be defined only by the first term of (6), i.e., $\nabla_{u_F}^T \mathcal{J}_F(u_L^d, u_F^d)(u_F^d - u_F) = 0$. By locally strict convexity of Λ_d at (u_L^d, u_F^d) and by exclusion of the possibility that $\Lambda_d = \{(u_L^d, u_F^d)\}$ [A.4] we know that it is not possible to also have $\nabla_{u_F} \mathcal{J}_F(u_L^d, u_F^d) = 0$. We can derive this from the first-order condition for strictly convex functions f , (Bertsekas (2003), Proposition B.3.) which states that $f(y) > f(x) + (y - x)^T \nabla f(x) \forall x, y \in \text{dom}(f), x \neq y$.

It follows that the normal vector defining the hyperplane $\Pi_{\Lambda_d}(u_L^d, u_F^d)$ is parallel to the decision space Ω_F , i.e., the hyperplane is orthogonal to $\{0\}^{n_L} \times \Omega_F$. Therefore,

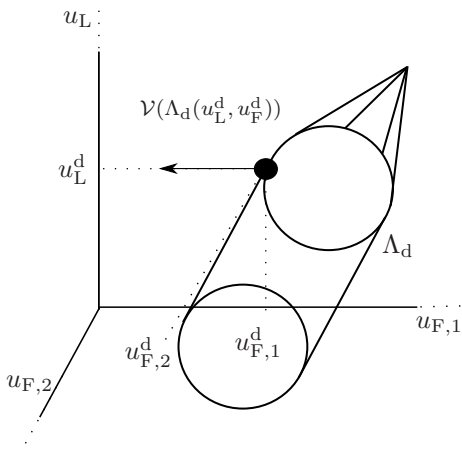

Fig. 2. Example of a convex set Λ_d nonsmooth at (u_L^d, u_F^d) , for which no optimal affine leader function exists.

$\text{proj}_{\Omega_F}(\Pi_{\Lambda_d}(u_L^d, u_F^d)) \not\supseteq \Omega_F$ and $\Pi_{\Lambda_d}(u_L^d, u_F^d)$ will not include any elements $(u_L, u_F) \in \Omega_L \times (\Omega_F \setminus \{u_F^d\})$, which implies that $\alpha_L^{\Pi_{\Lambda_d}}(\Omega_L) \subsetneq \Omega_F$.

(\Leftarrow) If $\nabla_{u_L} \mathcal{J}_F(u_L^d, u_F^d) \neq 0$, the normal vector $n_{\Pi_{\Lambda_d}(u_L^d, u_F^d)}$ defining the hyperplane $\Pi_{\Lambda_d}(u_L^d, u_F^d)$ is not orthogonal to the decision space Ω_L : $\text{proj}_{\Omega_L}(n_{\Pi_{\Lambda_d}(u_L^d, u_F^d)}) \neq \{0\}$. It follows that the hyperplane is not orthogonal to $\{0\}^{n_L} \times \Omega_F$: $\text{proj}_{\Omega_F}(\Pi_{\Lambda_d}(u_L^d, u_F^d)) = \Omega_F$.

Hence, $\forall u_F \in \Omega_F \exists u_L \in \Omega_L : (u_L, u_F) \in \Pi_{\Lambda_d}(u_L^d, u_F^d)$. Thus, there exists an affine $\alpha_L^{\Pi_{\Lambda_d}} : \alpha_L^{\Pi_{\Lambda_d}}(\Omega_L) = \Omega_F$ and therefore (u_L^d, u_F^d) can be reached under an affine leader function γ_L .

Remark 6. It should be noted that the differentiability requirement of \mathcal{J}_F could be replaced by the more general condition of Λ_d being smooth at (u_L^d, u_F^d) . In case \mathcal{J}_F is strictly convex, differentiability of \mathcal{J}_F indeed implies smoothness of Λ_d at (u_L^d, u_F^d) . However, in some cases \mathcal{J}_F may be nonsmooth in (u_L^d, u_F^d) , while Λ_d is in fact smooth. In this case, the gradient $\nabla \mathcal{J}_F(u_L^d, u_F^d)$ in Theorem 5 should be replaced by the normal vector to $\Lambda_d(u_L^d, u_F^d)$.

In the following theorem, the case where Λ_d is nonsmooth at (u_L^d, u_F^d) is considered. In addition, locally strict convexity of Λ_d at (u_L^d, u_F^d) is replaced with the more general property of a vertex point as discussed in Remark 3. An example of a case in which Λ_d is nonsmooth and no affine γ_L exists is depicted in Figure 2: here, $\text{proj}_{\Omega_L}(\mathcal{V}(\Lambda_d(u_L^d, u_F^d))) = \{0\}$.

Theorem 7. Let Λ_d be convex and let (u_L^d, u_F^d) be a vertex point. Additionally, let Λ_d be nonsmooth at (u_L^d, u_F^d) and assume that $\Omega_L = \mathbb{R}^{n_L}, \Omega_F = \mathbb{R}^{n_F}$. Then the desired equilibrium (u_L^d, u_F^d) can be reached under an affine $\gamma_L : \Omega_F \rightarrow \Omega_L$ if and only if $\text{proj}_{\Omega_L}(\mathcal{V}(\Lambda_d(u_L^d, u_F^d))) \neq \{0\}$.

Proof. Refer to the proof of Theorem 5 in combination with Remark 3 for the existence of an optimal affine $\alpha_L^{\Pi_{\Lambda_d}}$. It remains to show that in order for $\alpha_L^{\Pi_{\Lambda_d}}(\Omega_L) = \Omega_F$ to hold, it is necessary and sufficient that $\exists \nu \in \mathcal{V}(\Lambda_d(u_L^d, u_F^d)) : \text{proj}_{\Omega_L}(\nu) \neq \{0\}$, from which it follows that $\text{proj}_{\Omega_L}(\mathcal{V}(\Lambda_d(u_L^d, u_F^d))) \neq \{0\}$. This property can be

proven to be necessary and sufficient along the lines of the proof of Theorem 5 regarding $\nabla_{u_L} \mathcal{J}_F(u_L^d, u_F^d)$.

Remark 8. Consider the case described in Theorem 7 and in addition, let both inputs be scalar ($n_F = 1, n_L = 1$). For this special case an affine $\gamma_L : \Omega_F \rightarrow \Omega_L$ leading to (u_L^d, u_F^d) automatically exists.

Since Λ_d is nonsmooth at (u_L^d, u_F^d) , a supporting hyperplane to Λ_d will not be a unique (tangent) hyperplane. By both the convexity of Λ_d and by (u_L^d, u_F^d) being a vertex point, we know that $\nexists u_L \in \Omega_L \setminus \{u_L^d\} : \{(u_L, u_F^d)\} \in \Lambda_d$. Therefore there must exist an alternative normal vector defining the hyperplane $\Pi_{\Lambda_d}(u_L^d, u_F^d)$ that is not orthogonal to $\{0\}^{n_L} \times \Omega_F$. For such a vector, $\Pi_{\Lambda_d}(u_L^d, u_F^d)$ and therefore $\alpha_L^{\Pi_{\Lambda_d}(u_L^d, u_F^d)}$ will cover $\Omega_F : \text{dom}(\gamma_L) = \Omega_F$.

5. Λ_d NONCONVEX

In the current section, we show that in case the sublevel set Λ_d is allowed to be nonconvex, the results presented for the convex case may still apply if we consider the convex hull of Λ_d . Further, for the specific case where u_L is a scalar, a necessary and sufficient condition is provided for the use of an affine leader function. However, for $n_L > 1$ the concept of a supporting hyperplane used so far may be too restrictive, as will finally be considered in Proposition 14.

Lemma 9. A supporting hyperplane $\Pi_{\Lambda_d}(u_L^d, u_F^d)$ exists at (u_L^d, u_F^d) if and only if $(u_L^d, u_F^d) \notin \text{int}(\text{conv}(\Lambda_d))$. Further, for a vertex point (u_L^d, u_F^d) of $\text{conv}(\Lambda_d)$, $\Pi_{\Lambda_d}(u_L^d, u_F^d) \cap \Lambda_d = \{(u_L^d, u_F^d)\}$.

Proof. By definition of a convex hull, a supporting hyperplane $\Pi_{\Lambda_d}(u_L^d, u_F^d)$ exists if and only if there exists a supporting hyperplane $\Pi_{\text{conv}(\Lambda_d)}(u_L^d, u_F^d)$ to $\text{conv}(\Lambda_d)$ at (u_L^d, u_F^d) . Further, it is clear that a supporting hyperplane to $\text{conv}(\Lambda_d)$ exists at (u_L^d, u_F^d) if and only if (u_L^d, u_F^d) is a boundary point of $\text{conv}(\Lambda_d)$ and thus also of Λ_d (Rockafellar (1970), Theorem 11.6). Now, by definition, a vertex of $\text{conv}(\Lambda_d)$ is such a boundary point.

For an intersection of $\Pi_{\Lambda_d}(u_L^d, u_F^d)$ with Λ_d solely in the point (u_L^d, u_F^d) , it is required that (u_L^d, u_F^d) is a vertex point of $\text{conv}(\Lambda_d)$. (Note that it is therefore sufficient for $\text{conv}(\Lambda_d)$ to be locally strictly convex around (u_L^d, u_F^d) .)

5.1 $n_L = 1$

Lemma 10. Assume there exists a strictly supporting hyperplane $\Pi_{\text{conv}(\Lambda_d)}(u_L^d, u_F^d) : \Pi_{\text{conv}(\Lambda_d)}(u_L^d, u_F^d) \cap \Lambda_d = \{(u_L^d, u_F^d)\}$. Then an affine $\alpha_L^{\Pi_{\text{conv}(\Lambda_d)}(u_L^d, u_F^d)}$ coincides with $\Pi_{\text{conv}(\Lambda_d)}(u_L^d, u_F^d)$ if and only if u_L is scalar ($n_L = 1$).

Proof. Only in case of u_L scalar the dimension of a hyperplane Π_{Λ_d} , i.e., $(n_L + n_F) - 1$, equals the number of independent variables, n_F , of an affine leader function. If there exists a strictly supporting hyperplane $\Pi_{\text{conv}(\Lambda_d)}(u_L^d, u_F^d)$, it follows that this plane coincides with $\alpha_L^{\Pi_{\text{conv}(\Lambda_d)}(u_L^d, u_F^d)}$.

Lemma 10 implies that for $n_L > 1$ and for Λ_d nonconvex, requiring $\alpha_L \in \mathcal{A}_L$ to lie on a supporting hyperplane

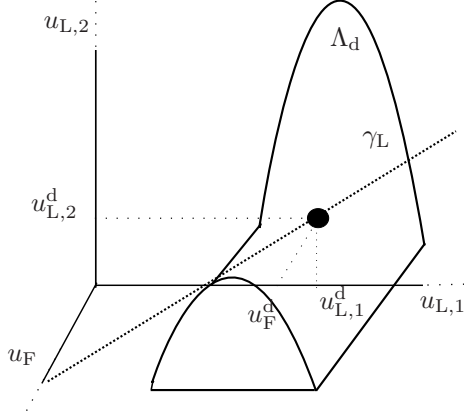

Fig. 3. Example of an optimal affine leader function γ_L not lying on a supporting hyperplane $\Pi_{\Lambda_d}(u_L^d, u_F^d)$ for $n_L > 1$, $(u_L^d, u_F^d) \in \text{int}(\text{conv}(\Lambda_d))$.

separating the full $(n_F + n_L)$ -dimensional decision space is generally too restrictive for the existence of an optimal affine leader function. This applies to e.g., the case where $(u_L^d, u_F^d) \in \text{int}(\text{conv}(\Lambda_d))$ as depicted in Figure 3. Still, it is necessary that coverage of Ω_F is achieved by an affine $\alpha_L \in \mathcal{A}_L$ in the sense that $\alpha_L(\Omega_L) = \Omega_F$, and that the associated $\gamma_L : \Omega_F \rightarrow \Omega_L$ does not intersect Λ_d in any other point than (u_L^d, u_F^d) . Hence, instead of using the supporting hyperplane concept, a condition will be developed based on a tangent hyperplane (Proposition 14). However, we first extend the results of Theorem 5 and 7 to the cases with respectively Λ_d nonconvex and nondifferentiable at (u_L^d, u_F^d) , for $n_L = 1$.

Proposition 11. Let $\text{conv}(\Lambda_d)$ be locally strictly convex at (u_L^d, u_F^d) and assume that $n_L = 1$. Additionally, let \mathcal{J}_F be differentiable at (u_L^d, u_F^d) and let $\Omega_L = \mathbb{R}^{n_L}, \Omega_F = \mathbb{R}^{n_F}$. Then the desired equilibrium (u_L^d, u_F^d) can be reached under an affine $\gamma_L : \Omega_F \rightarrow \Omega_L$ if and only if it both holds that $(u_L^d, u_F^d) \notin \text{int}(\text{conv}(\Lambda_d))$ and that $\nabla_{u_L} \mathcal{J}_F(u_L^d, u_F^d) \neq 0$.

Proof. First note that since $n_L = 1$, an affine $\alpha_L \in \mathcal{A}_L$ coincides with the supporting hyperplane $\Pi_{\text{conv}(\Lambda_d)}(u_L^d, u_F^d)$, as shown in Lemma 10. Further, by Lemma 9, a supporting hyperplane $\Pi_{\text{conv}(\Lambda_d)}(u_L^d, u_F^d)$ exists if and only if $(u_L^d, u_F^d) \notin \text{int}(\text{conv}(\Lambda_d))$. For the remainder of the proof we refer to the proof of Theorem 5 where Λ_d should be replaced by $\text{conv}(\Lambda_d)$, and where Lemma 9 is used as the nonconvex equivalent to Lemma 2.

In the following proposition, differentiability of \mathcal{J}_F is again relaxed and locally strict convexity of Λ_d at (u_L^d, u_F^d) is replaced with the more general property of a vertex point as discussed in Remark 3.

Proposition 12. Let (u_L^d, u_F^d) be a vertex point of $\text{conv}(\Lambda_d)$ and assume that $n_L = 1$. Additionally, allow Λ_d to be nonsmooth at (u_L^d, u_F^d) and assume that $\Omega_L = \mathbb{R}^{n_L}, \Omega_F = \mathbb{R}^{n_F}$. Then the desired equilibrium (u_L^d, u_F^d) can be reached under an affine $\gamma_L : \Omega_F \rightarrow \Omega_L$ if and only if $\text{proj}_{\Omega_L}(\mathcal{V}(\text{conv}(\Lambda_d)(u_L^d, u_F^d))) \neq \{0\}$.

Proof. Note that since (u_L^d, u_F^d) is a vertex point of $\text{conv}(\Lambda_d)$, it is automatically satisfied that $(u_L^d, u_F^d) \notin$

$\text{int}(\text{conv}(\Lambda_d))$. Hence by Lemma 9 a supporting hyperplane exists that in addition contains only (u_L^d, u_F^d) of the set Λ_d .

For the remainder of the proof we refer to the proof of Theorem 7 where Λ_d should be replaced by $\text{conv}(\Lambda_d)$, and where the proof of Proposition 11 is used as the nonconvex equivalent to Theorem 5.

5.2 $n_L > 1$

Proposition 13. Let $n_L > 1$ and assume that (u_L^d, u_F^d) is a vertex point of $\text{conv}(\Lambda_d)$. Allow Λ_d to be nonsmooth at (u_L^d, u_F^d) and assume that $\Omega_L = \mathbb{R}^{n_L}, \Omega_F = \mathbb{R}^{n_F}$. Then the desired equilibrium (u_L^d, u_F^d) can be reached under an affine $\gamma_L : \Omega_F \rightarrow \Omega_L$ if and only if $\text{proj}_{\Omega_L}(\mathcal{V}(\text{conv}(\Lambda_d)(u_L^d, u_F^d))) \neq \{0\}$.

Proof. Refer to the proof of Theorem 7, but where the convex set Λ_d is replaced by $\text{conv}(\Lambda_d)$. As discussed in Lemma 9, since (u_L^d, u_F^d) is a vertex point we know that $\exists \Pi_{\text{conv}(\Lambda_d)}(u_L^d, u_F^d) : \Pi_{\text{conv}(\Lambda_d)}(u_L^d, u_F^d) \cap \Lambda_d = \{(u_L^d, u_F^d)\}$.

Proposition 14. Let $n_L > 1$ and assume that $(u_L^d, u_F^d) \in \text{int}(\text{conv}(\Lambda_d))$. Allow Λ_d to be nonsmooth at (u_L^d, u_F^d) and assume that $\Omega_L = \mathbb{R}^{n_L}, \Omega_F = \mathbb{R}^{n_F}$. Then the desired equilibrium (u_L^d, u_F^d) can be reached under an affine $\gamma_L : \Omega_F \rightarrow \Omega_L$ if and only if there exists an n_F -dimensional tangent, affine subspace $\Pi_d^t(u_L^d, u_F^d)$ to Λ_d at (u_L^d, u_F^d) such that $\Pi_d^t(u_L^d, u_F^d) \cap \Lambda_d = \{(u_L^d, u_F^d)\}$ and such that $\text{proj}_{\Omega_L}(\mathcal{V}(\Lambda_d(u_L^d, u_F^d))) \neq \{0\}$.

Proof. First note that because $\alpha_L \in \mathcal{A}_L$ is of the same dimension as the tangent, affine subspace $\Pi_d^t(u_L^d, u_F^d)$, it holds that $\exists \alpha_L : \alpha_L \cap \Lambda_d = \{(u_L^d, u_F^d)\}$ if and only if $\exists \Pi_d^t(u_L^d, u_F^d) : \Pi_d^t(u_L^d, u_F^d) \cap \Lambda_d = \{(u_L^d, u_F^d)\}$.

Additionally, given that an optimal affine $\alpha_L \in \mathcal{A}_L$ exists, in order for α_L to be a mapping $\Omega_F \rightarrow \Omega_L$ it is sufficient and necessary that $\text{proj}_{\Omega_L}(\mathcal{V}(\Lambda_d(u_L^d, u_F^d))) \neq \{0\}$ as proven before in e.g., Theorem 7.

Finally, note that Remark 4, 6, and 8 of Section 4 – the latter for $(u_L^d, u_F^d) \notin \text{int}(\text{conv}(\Lambda_d))$ – also translate to the case in which Λ_d is nonconvex.

6. CONSTRAINED DECISION SPACE

So far the unbounded case is considered and conditions have been provided under which an optimal affine leader function exists that leads to the desired equilibrium. In the constrained case however, the complexity arises that additionally $\Pi_{\Lambda_d}(u_L^d, u_F^d)$ – or $\Pi_{\Lambda_d}^t(u_L^d, u_F^d)$ for the case with $n_L > 1$ and $(u_L^d, u_F^d) \in \text{int}(\text{conv}(\Lambda_d))$ – should be within the constrained decision space $\Omega_L \times \Omega_F$. This implies that the supporting or tangent hyperplane should contain an n_F -dimensional affine subspace γ_L satisfying (I) $\gamma_L(\Omega_F) \subseteq \Omega_L$ while (II) γ_L should cover Ω_F , i.e., $\text{dom}(\gamma_L) = \Omega_F$.

For this constrained case with Λ_d convex, Theorem 5 and 7 pose necessary – but not necessarily sufficient – conditions for \mathcal{J}_F smooth and for Λ_d nonsmooth at (u_L^d, u_F^d) , respectively. The same applies to Propositions 11–14 that hold for Λ_d nonconvex.

7. CONCLUSION AND FURTHER RESEARCH

We have studied necessary and sufficient conditions under which an affine leader function can solve the single-leader single-follower deterministic static reverse Stackelberg game to optimality for a particular desired leader equilibrium. While in the literature the focus is on a special class of problems, we have developed more general conditions and extended the existing results by considering nonconvex and nonsmooth sublevel sets. These conditions can be used for further derivation of an optimal leader function and they therefore provide a basic step towards developing a systematic approach for solving more general subclasses of the complex reverse Stackelberg game.

Topics for future research include the investigation of a more diverse class of nonlinear leader functions, e.g., piecewise-affine and smooth (piecewise) polynomial structures, and the formulation of sufficient conditions in case of a constrained decision space. The development of numerical derivation methods for the leader function could facilitate the formulation of such conditions. Here, the development of a tractable solution approach of the reverse Stackelberg game will be a focal point of continued research, to-be-applied in applications like road tolling.

ACKNOWLEDGEMENTS

Research supported by the BSIK project “Next Generation Infrastructures (NGI)”, the European Union Seventh Framework Programme [FP7/2007-2013] under grant agreement no. 257462 HYCON2 Network of Excellence, and by the European COST Actions TU1102 and TU0702.

REFERENCES

- Åström, K.J. and Wittenmark, B. (1997). *Computer-Controlled Systems – Theory and Applications*. Prentice Hall, Upper Saddle River, NJ, USA, 3rd edition.
- Auslender, A. and Teboulle, M. (2003). *Asymptotic Cones and Functions in Optimization and Variational Inequalities*. Springer monographs in mathematics. Springer, New York, NY, USA.
- Başar, T. (1984). Affine incentive schemes for stochastic systems with dynamic information. *SIAM Journal on Scientific and Statistical Computing*, 22, 199–210.
- Başar, T., Bensoussan, A., and Sethi, S.P. (2010). Differential games with mixed leadership: The open-loop solution. *Applied Mathematics and Computation*, 217(3), 972–979.
- Başar, T. and Olsder, G.J. (1999). *Dynamic Noncooperative Game Theory*. Classics in Applied Mathematics. SIAM, Philadelphia, 2nd edition.
- Bertsekas, D.P. (2003). *Nonlinear Programming*. Athena Scientific, Belmont, MA, USA, 2nd edition.
- Cansever, D.H. and Başar, T. (1985a). On stochastic incentive control problems with partial dynamic information. *Systems & Control Letters*, 6(1), 69–75.
- Cansever, D.H. and Başar, T. (1985b). Optimum/near optimum incentive policies for stochastic decision problems involving parametric uncertainty. *Automatica*, 21(5), 575–584.
- Clarke, F.H. (1983). *Optimization and Nonsmooth Analysis*. Wiley-Interscience, New York, NY, USA.
- Dattorro, J. (2005). *Convex Optimization & Euclidean Distance Geometry*. Meboo Publishing USA, Palo Alto, CA, USA.
- Ehtamo, H. and Hämäläinen, R.P. (1985). Construction of optimal affine incentive strategies for linear-quadratic Stackelberg games. In *Proceedings of the 24th IEEE Conference on Decision and Control*, 1093–1098. Fort Lauderdale, FL, USA.
- Ho, Y.C., Luh, P.B., and Muralidharan, R. (1981). Information structure, Stackelberg games, and incentive controllability. *IEEE Transactions on Automatic Control*, 26(2), 454–460.
- Ho, Y.C., Luh, P.B., and Olsder, G.J. (1982). A control-theoretic view on incentives. *Automatica*, 18(2), 167–179.
- Li, M., Cruz, Jr., J.B., and Simaan, M.A. (2002). An approach to discrete-time incentive feedback Stackelberg games. *IEEE Transactions on Systems, Man, and Cybernetics - Part A: Systems and Humans*, 32(4), 472–481.
- Luh, P.B., Ho, Y.C., and Muralidharan, R. (1982). Load adaptive pricing: An emerging tool for electric utilities. *IEEE Transactions on Automatic Control*, 27(2), 320–329.
- Nie, P.y. (2010). Discrete time dynamic Stackelberg games with the leaders in turn. *Nonlinear Analysis: Real World Applications*, 11(3), 1685–1691.
- Olsder, G.J. (2009). Phenomena in inverse Stackelberg games, part 1: Static problems. *Journal of Optimization Theory and Applications*, 143(3), 589–600.
- Rockafellar, R.T. (1970). *Convex Analysis*. Princeton University Press, Princeton, NJ, USA.
- Salman, M.A. and Cruz, Jr., J.B. (1983). Team-optimal closed-loop Stackelberg strategies for systems with slow and fast modes. *International Journal of Control*, 37(6), 1401–1416.
- Scattolini, R. (2009). Architectures for distributed and hierarchical model predictive control: A review. *Journal of Process Control*, 19(5), 723–731.
- Shen, H. and Başar, T. (2007). Incentive-based pricing for network games with complete and incomplete information. In S. Jørgensen, M. Quincampoix, and T. Vincent (eds.), *Advances in Dynamic Game Theory*, volume 9 of *Annals of the International Society of Dynamic Games*, 431–458. Birkhäuser Boston, New York, NY, USA.
- Simaan, M. and Cruz, Jr., J.B. (1973). On the Stackelberg strategy in nonzero-sum games. *Journal of Optimization Theory and Applications*, 11(5), 533–555.
- Staňková, K., Olsder, G.J., and Bliemer, M.C.J. (2009). Comparison of different toll policies in the dynamic second-best optimal toll design problem: Case study on a three-link network. *European Journal of Transport and Infrastructure Research*, 9(4), 331–346.
- Tolwinski, B. (1981). Closed-loop Stackelberg solution to a multistage linear-quadratic game. *Journal of Optimization Theory and Applications*, 34(4), 485–501.
- von Stackelberg, H. (1934). *Marktform und Gleichgewicht*. Julius Springer, Vienna, Austria.
- Zheng, Y.P. and Başar, T. (1982). Existence and derivations of optimal affine incentive schemes for Stackelberg games with partial information: A geometric approach. *International Journal of Control*, 35(6), 997–1011.